

# Ultimate Access XL E & V

XL recessed electric screen with motorized closure



## INSTRUCTIONS INSTALLATION & OPERATION

### Overview - Components

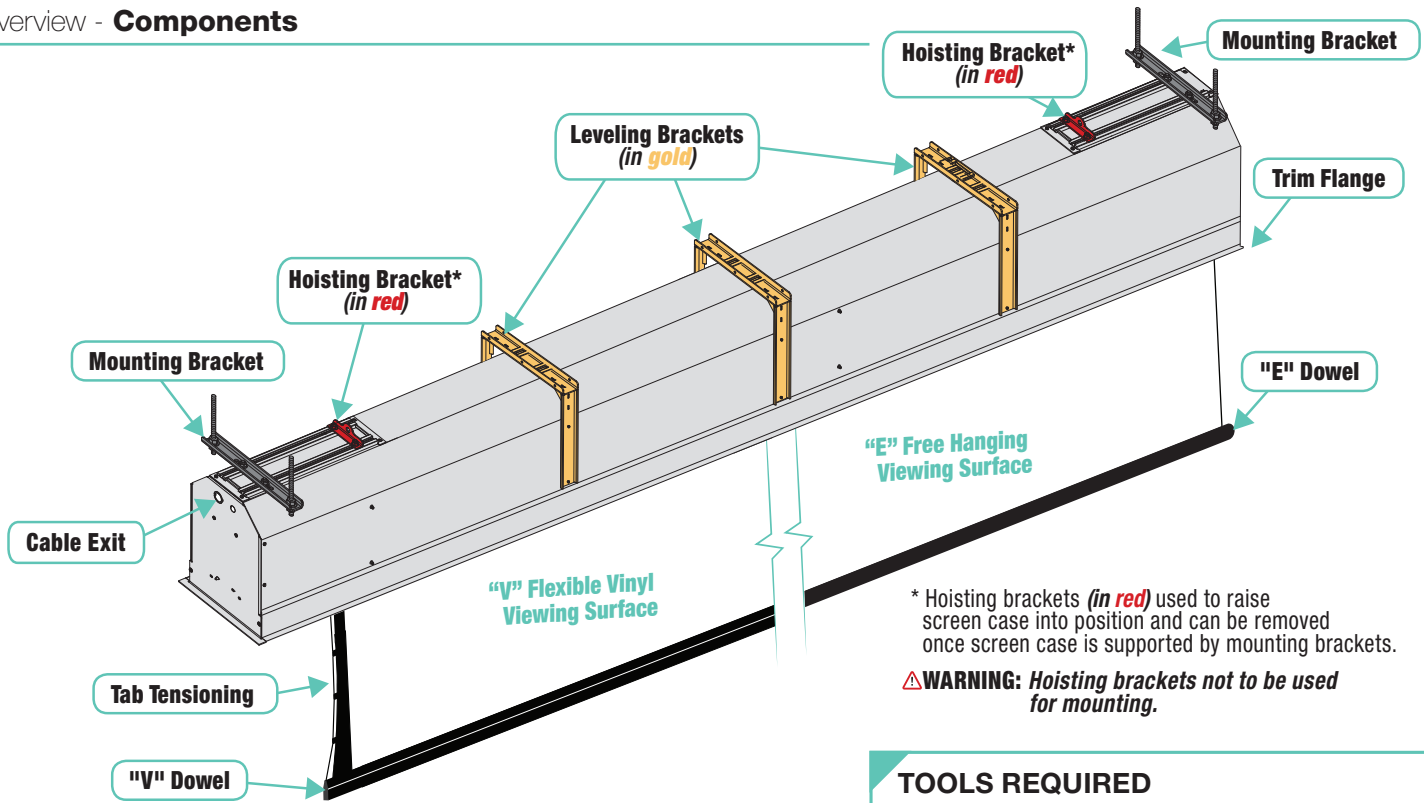

\* Hoisting brackets (in red) used to raise screen case into position and can be removed once screen case is supported by mounting brackets.  
**⚠ WARNING: Hoisting brackets not to be used for mounting.**

**Shipping Brackets Attached to Dowel and Screen Case**  
*(V Screens Only)*

**Please Note:** Shipping brackets must remain in place until product has been mounted and connected to power (see Sections 1 and 4 in this document.).

Also, DO NOT operate screen before removing shipping brackets from screen case.

**TOOLS REQUIRED**

- PENCIL
- POWER DRILL
- TAPE MEASURE
- HARDWARE (by others)
- LEVEL

**⚠ CAUTION ⚠**  
 Read and understand all warnings (page 2) before beginning installation.

**Contents**

Overview - Components.....	1	Section 7 - Tab-Tension Adjustment Procedure.....	5
Section 1 - Removing Shipping Brackets (Tab-Tensioned, "V" Surfaces only) .....	2	Section 7 - Limit Adjustments.....	5
PLEASE READ - Safety Information.....	2	Section 8 - Electrical Connections .....	5
Section 2 - Hanging Screen.....	3	Section 8 - Case Length Dimensions .....	6
Section 3 - Bottom Access Panel/Trap Door Opening and Closing.....	3	Section 9 - Case Width Dimensions.....	6
Section 4 - Motorized Roller/Fabric Installation.....	4	Section 10 - Mounting Bracket Dimensions .....	6
Section 5 - Motorized Roller/Fabric Removal .....	4	Section 11 - Wiring Diagrams 110-120V Motor .....	7
Section 6 - Operation .....	5		

If you have any difficulties installing or servicing your Ultimate Access XL screen, call your dealer or Draper, Inc.



## Section 1 - Removing Shipping Brackets (Tab-Tensioned, "V" Surfaces only)

**CAUTION:** DO NOT remove shipping brackets until product has been mounted and connected to power (see Section 4 in this document.). Also, DO NOT OPERATE SCREEN BEFORE REMOVING SHIPPING BRACKETS FROM SCREEN CASE.

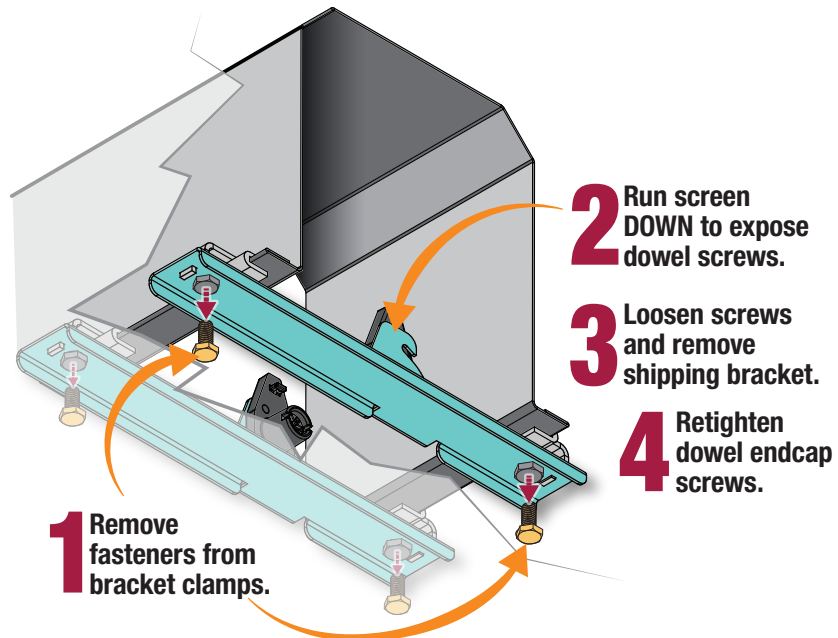

## PLEASE READ - Safety Information

### Important Safety Information



### Important Safety Information

**Improper installation and use of the Ultimate Access XL Projection Screen can result in serious injury or death. Primarily, injuries can occur if the unit falls due to imprecise installation, mishandling of the unit during installation, or installation on an insufficient wall or ceiling structure. Please use extreme care.**

1. Please read the following installation guidelines thoroughly and follow them carefully. Failure to do so may cause product to fall or otherwise fail, and could result in serious injury.
2. Installation and calibration of the unit should only be performed by an authorized, qualified, and experienced professional. In particular, electrical work and wiring [indicated in diagram by dashed lines] must be completed only by a qualified professional electrician who has read this manual completely and is familiar with the construction and operation of this equipment and the hazards involved.
3. Do not affix the unit to walls or ceilings that have inadequate strength to permanently hold the unit during use. It is the owner's and installer's responsibility to confirm the wall or ceiling to which the unit attaches is sufficient to permanently hold the weight and stress loads of the unit at all times. Draper, Inc., is not responsible for improper installation, application, testing, or workmanship related to the product at place of installation.
4. It is the installer's responsibility to make sure appropriate fasteners are used for mounting.
5. All hardware must be installed level. Unit must be level and square.
6. Never leave the area while operating the unit during installation, maintenance, or normal operation, unless it is secure and safe.
7. Before testing or operation, carefully inspect the entire area and path (especially underneath) of unit to be sure no persons or objects are in the area.
8. Turn off power and any nearby equipment or cables carrying electricity before connecting switches, wires, controls, or electrical components.
9. Do not wire motors in parallel without written permission from Draper, Inc.
10. During testing or operation, carefully watch the surrounding area for any potential safety concerns including nearby persons or objects.
11. After installation, the entire system, including all sensors, should be carefully tested to ensure safe and normal operation. Extreme care should be taken during testing to remain clear of moving parts to avoid possible injury.
12. Operation of unit should be performed only by authorized and qualified personnel, who have been trained in its safe and effective operation and understand its safety features.
13. The safety features of the unit should never be disabled, bypassed, or overridden. The system should not be operated until all safety features are properly and completely installed, calibrated, and tested.
14. Unit may need to comply with local, state, or district rules and regulations, in particular when installed in schools. All applicable rules and regulations should be reviewed before installation and use.
15. **Failure to precisely follow installation guidelines invalidates all warranties.**
16. Custom products/installations may not be reflected in this manual. Call Draper, Inc., if you have questions about the installation of custom products or any questions about your installation.

### Before Beginning Installation

1. Look for any job site conditions that could interfere with installation or operation of the system.
2. Read carefully and be sure to understand all installation instructions and all related operations manuals. These instructions are intended to serve as a guide for the installer and owner. They should be followed closely and combined with the expertise of experienced qualified installers. Draper, Inc., is not responsible for improper installation, application, testing, or workmanship related to the product at place of installation. Please retain all instructions for future use.
3. Open cartons lengthwise.
4. Locate and lay out all pieces.
5. Inspect all boxes to make sure you have received the proper unit and parts. Controls may be shipped separately, or in same carton as unit.
6. If you have any difficulties with installing, servicing, or operating your unit, call your dealer or Draper, Inc., 765-987-7999.

## Section 2 - Hanging Screen

**Please Note:** When locating viewing surface and checking clearance for screen operation, ensure that surface is centered in the case.

1. Engage each case mounting bracket (*attached to case*) with top of housing (*Fig. 2*) and tighten set screws.
2. Screen should be sufficiently supported to withstand vibration.

**Please Note:** A hoisting bracket is included on each end of the case to aid in overhead installation.

3. Ensure that fasteners are of adequate strength and suitable for the mounting surface chosen. Supporting hardware such as chains, cables, two  $\frac{3}{8}$ " (9.5 mm) rods, etc., must be **precisely** vertical.
4. Entire bottom of case must be readily accessible after installation is complete.
5. Front, back, and top of case must be straight—not forced to warp or bow.

**CAUTION:** Screen case and flange are not designed to serve as ceiling support.

6. Do not seal unit in ceiling until electrical connections have been made and screen operates successfully.

**Please Note:** If case is painted on location, removal of roller/fabric assembly is recommended prior to painting. If not removed, slot on bottom of case should be shielded to protect viewing surface from paint splatters/overspray.

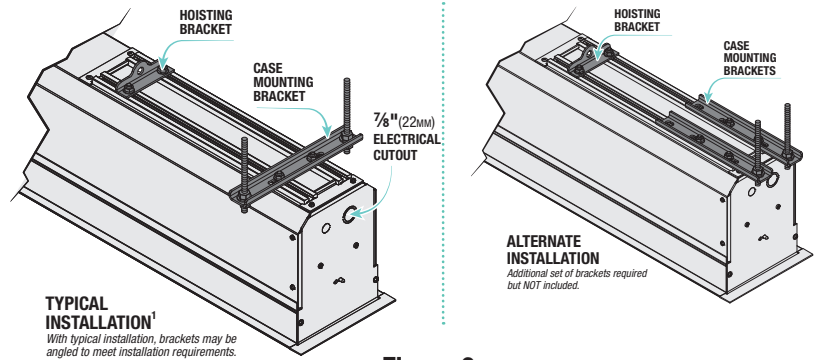

**Figure 2**

**Please Note:** Extra brackets must be ordered for alternate installation.

## Section 3 - Bottom Access Panel/Trap Door Opening and Closing

1. To access inside of screen case, disengage spring latch at center, followed by latches at each end.
2. To disengage, slide latch lever towards center of screen case (*Fig.3*), then pull down gently on trap door assembly.

**Please Note:** Latch levers are somewhat concealed from view. Locate with trap door open by feeling for vertical latch lever above door about 3" (76mm) from case endcaps and near center of case.

3. Assembly will swing down and open (*about 135°*).
4. Pivot prop arms at each end of trap door assembly. Prop arms will engage with a hole in each endcap to hold trap door assembly fully open. To close trap door assembly disengage prop arms from endcaps and pivot over access panel.

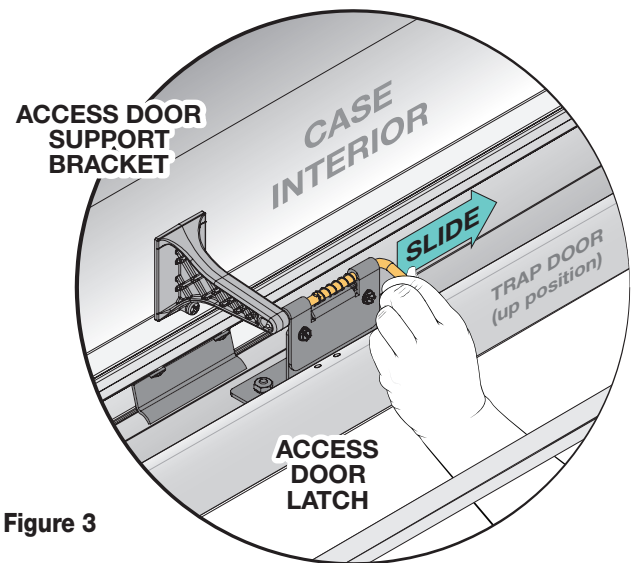
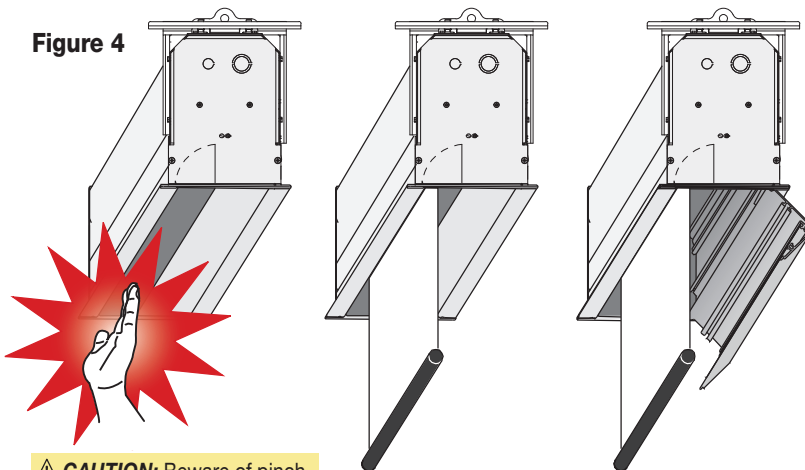

**Figure 3**

5. Swing trap door assembly upward, stopping just before latch levers hit bottom flanges of endcaps (*and center of case where appropriate*).
6. Pull latch levers toward center of screen case to allow trap door assembly to be pivoted to its closed position.

**Please Note:** Ensure that latch levers engage fully with case endcaps (*and center of case where appropriate*).

**Figure 4**



**CAUTION:** Beware of pinch points along closure.

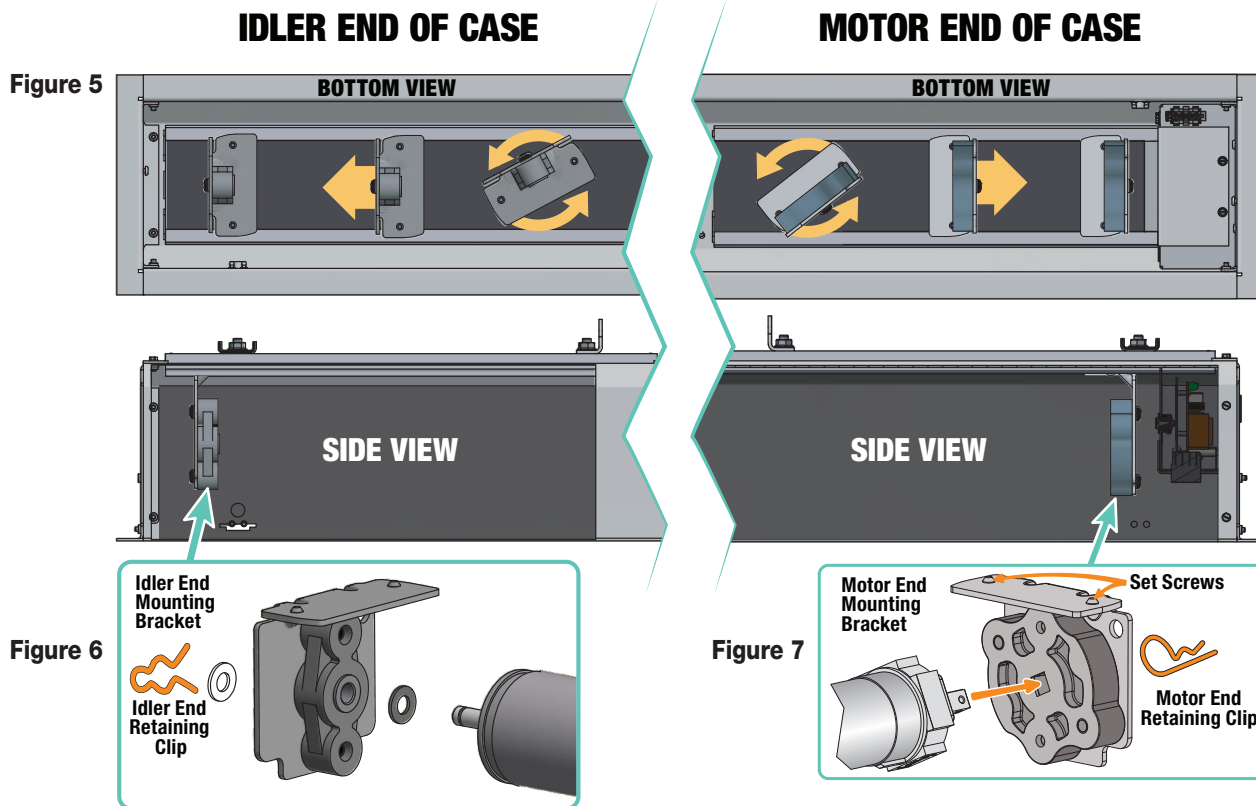

## Section 4 - Motorized Roller/Fabric Installation

1. Remove bottom access panel (See Section 3).
  2. Back out set screws from top side of motor mounting brackets (See Fig. 5 & 7).
  3. To engage motor end bracket flange (above the two channels in the top of the screen housing), rotate bracket approximately 45° counterclockwise to allow top surface of motor bracket to rest flat against top inside housing.
  4. Rotate bracket clockwise until it engages in channel.
  5. Engage idler end bracket in same manner as motor end bracket and slide toward opposite end of screen housing.
- ⚠ Caution:** Step 6 requires two people to perform safely.
6. Locate retaining clips attached to instruction sheet. Lift roller/fabric assembly into screen housing and engage motor head completely into motor bracket, making sure limit switch adjusting knobs are visible from bottom of screen housing (Fig. 7).
- Please Note:** If snap ring is provided, make sure it engages with motor. If retaining clip is provided instead, install to lock motor end in place.
7. Support idler end of roller and slide mounting bracket toward roller. Insert roller pin into nylon bushing on idler bracket (Fig. 6).
  8. Roller idler pin goes through idler bracket. Reinstall washer and retaining clip.
- ⚠ Caution:** Failure to replace washer and retaining clip could result in separation of roller from brackets.
9. Center roller/fabric assembly by sliding mounting brackets left or right.
  10. Securely tighten set screws on roller mounting brackets.
  11. Connect electrical plug from motor to mating socket on junction box.
  12. Attach door support brackets
  13. Reinstall bottom access panel as previously described.

## Section 5 - Motorized Roller/Fabric Removal

Reverse the previous instructions ("Motorized Roller/Fabric Installation") for removal of unit.

## Section 6 - Operation

**CAUTION:** When operating for the first time, cycle unit down and up several times to confirm satisfactory operation. Be prepared to cut POWER if necessary.

- **110-120V SINGLE STATION CONTROL** - 3-position UP-OFF-DOWN switch permits operation to be stopped at any point. Factory adjusted limit switches automatically stop screen when fully down or fully up.
- **24V CONTROL** - 3-button UP-STOP-DOWN switches stop at any point desired and operate in any sequence. Factory adjusted limit switches automatically stop screen when fully up or fully down. Installer should incorporate an all-pole disconnect in fixed wiring available with RF or IR remote.
- **RS232 / ETHERNET** - Serial communication and network communication optionally available.
- **KEY OPERATED SWITCHING** - Two key-operated switches optionally available with this unit:
  - **Key-operated power supply switch** controls power to screen and switches. When switch is in the "off" position, screen will not operate. Key may be removed from switch in either "on" or "off" position.
  - **Three-position key switch** permits the screen to be operated directly by key. Requires screen operator to have a key.

## Section 7 - Tab-Tension Adjustment Procedure

**Please Note:** Draper's Tab-Tensioning System is factory-set, and under normal circumstances will not require field adjustment. If wrinkles are observed, however, follow the adjustment procedure shown in Figure 8.

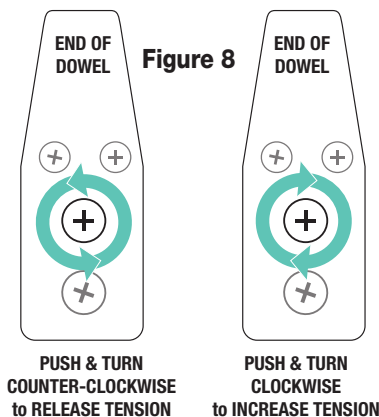

## Section 8 - Electrical Connections

1. Screen operates on 110-120V, 60 Hz., 1.1-amp current draw.
2. Junction box is located just above the bottom access panel at the left end of the screen.
3. Open the access panel/trap door for access to the junction box cover. (See bottom access panel/trap door opening and closing instructions below).
4. Remove two (2) hex head screws that secure the cover to the junction box to expose the red, black, and white pigtail leads and the green ground wire per wiring diagram (Page 7).
5. If optional low-voltage control or video interface control is specified and factory installed, please refer to wiring diagrams (Page 7).
6. Screen ships with internal wiring complete and control switch(es) fully boxed. Wire to connect screen to switch(es) and switch(es) to power supply should be furnished by installer. Connections should be made in accordance with attached wiring diagram, and wiring should comply with national and local electrical codes.
7. All operating switches should be "off" before power is connected.

## Section 9 - Limit Adjustments

**Please Note:** Screen limits are factory set for optimum performance of the screen. Any adjustment of these limits could void the warranty. Please check with Draper prior to resetting screen limits.

**Please Note:** If Screen is "Right Hand Motor" the WHITE/DOWN (I) and YELLOW/UP (II) limit screws are reversed (Fig. 10).

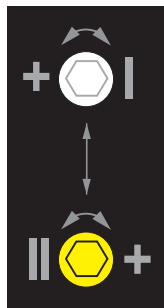

**Figure 9**  
**DOWN Limit (I):**  
Clockwise decreases down travel.

**UP Limit (II):**  
Counterclockwise increases up travel.

### "Down" Limit Adjustment (requires 3/32" (4 mm) hex key)

#### To Reduce Screen Drop:

1. Raise screen surface approximately 1' (30 cm) above desired setting and turn off.
2. Turn DOWN (I) limit screw clockwise (3 screw turns = 1/2 roller revolution).
3. Test by lowering screen. Repeat steps 1 & 2 until desired position is reached.

#### To Increase Screen Drop:

1. Lower screen to down limit.
2. With down switch on, turn DOWN (I) limit screw counterclockwise (3 screw turns = 1/2 roller revolution) to increase drop.
3. Test by raising screen approximately 1' (30 cm) then lower to new down limit.
4. Repeat steps 2 and 3 until desired position reached.

### "Up" Limit Adjustment

#### If Screen Raises Too High:

1. Lower screen surface approx. 1' (30 cm) below desired setting and turn off.
2. Turn UP (II) limit screw clockwise (3 screw turns = 1/2 roller revolution).
3. Test by advancing screen up.
4. Repeat steps 1 through 3 until desired position is reached.

#### If Screen Needs to Raise Higher:

1. Lower screen surface approx. 1' (30 cm) below desired setting and turn off.
2. With UP switch on, turn UP (II) limit screw counterclockwise (3 screw turns = 1/2 roller revolution).
3. Repeat steps 1 and 2 until desired position is reached.

### CAUTION:

- Be sure all switches are in "off" position before adjusting limit switches.
- Be prepared to shut off manually while testing.
- Screen may be damaged by lowering it too far and exposing roller.
- Motor must be installed so that limit switches are pointed down.

**Figure 10**

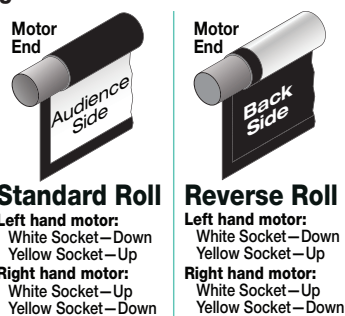

**Standard Roll**  
Left hand motor:  
White Socket—Down  
Yellow Socket—Up  
Right hand motor:  
White Socket—Up  
Yellow Socket—Down

**Reverse Roll**  
Left hand motor:  
White Socket—Down  
Yellow Socket—Up  
Right hand motor:  
White Socket—Up  
Yellow Socket—Down

**CAUTION:**  
DO NOT allow dowel to wrap over roller when operating screen! This could damage screen.

## Section 8 - Case Length Dimensions

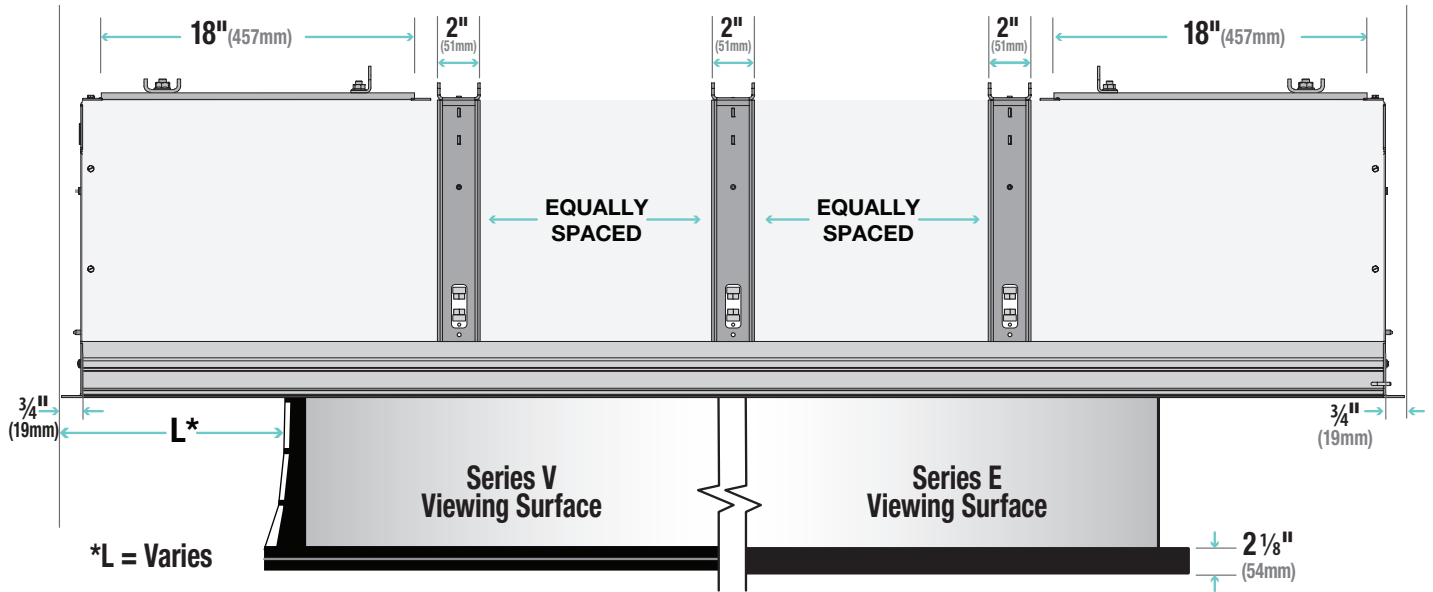

- For minimum length of ceiling cutout: subtract 1 1/4" (32mm) from case length (measured from outer edge of flanges).
- For minimum width of cutout (front to back): see case width dimensions below.
- \*\*Leveling brackets are used to level the case and should NOT be used to support the weight of the unit.
- The leveling brackets are riveted to the side of the case. Hardware used for leveling provided by others.

## Section 9 - Case Width Dimensions

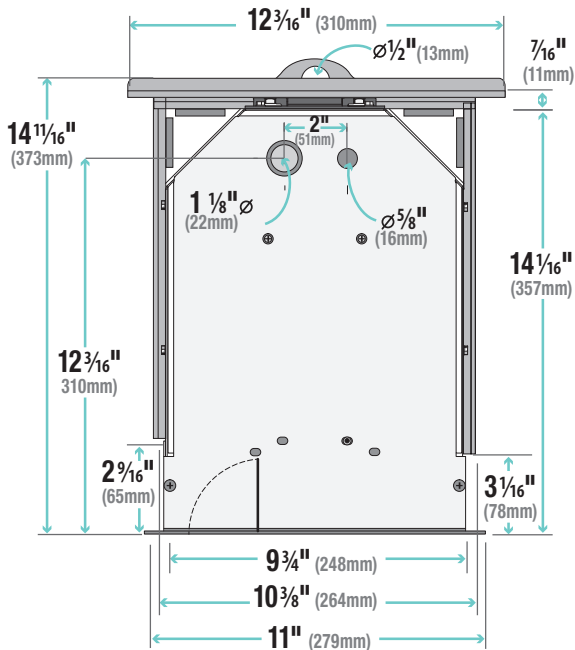

Standard Motor Wiring is on the AUDIENCE LEFT END of Screen Case.

## Section 10 - Mounting Bracket Dimensions

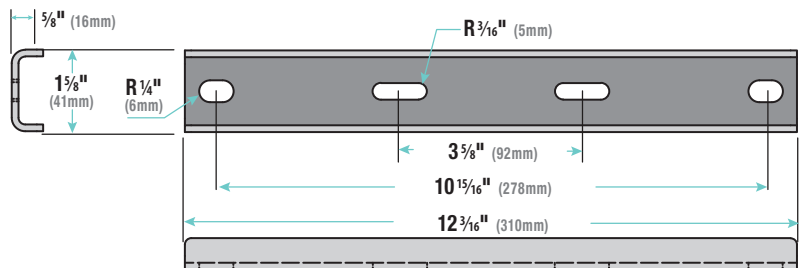

## Section 11 - Wiring Diagrams 110-120V Motor

**Please Note:** Do not wire motors in parallel.

### STANDARD Single Station Control

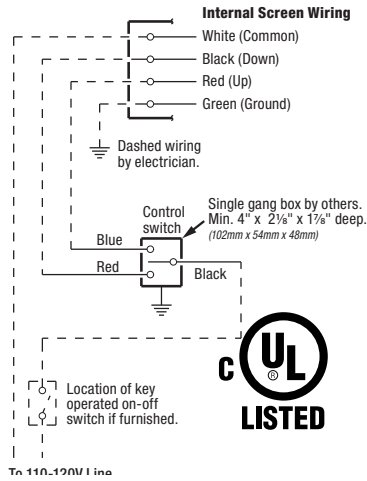

\* These wiring diagrams are for Access screens with motor on audience left (standard), and fabric unrolling from the back of the roller (standard).

### Internal LVC-IV - Single or Multiple Projection Screen Wiring Diagram

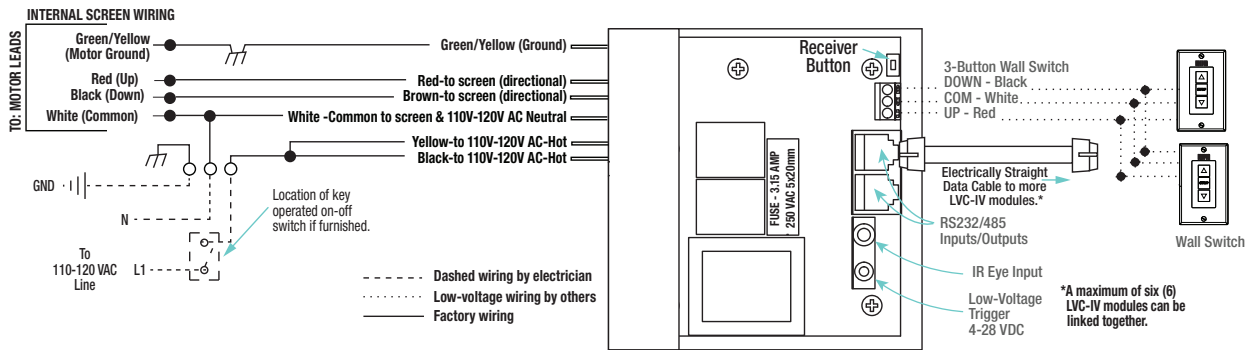

### External LVC-IV - Single or Multiple Projection Screen Wiring Diagram

