

Premier C

Crank-Operated Screen With Perfectly Flat Viewing Surface

SUBMITTAL TECHNICAL INFO

Specifications *Please check all appropriate selections and attach room schedule with verified dimensions.*

Projection screens, size _____ h. x _____ w., 3" dia. metal roller. Operated by detachable polished aluminum crank. Viewing surface to be flame and mildew resistant, with black masking borders. Each side of surface to have tab-guide cable system to maintain even lateral tension and hold surface flat. Bottom of surface supported and masked by black, extruded aluminum dowel weighted to apply proper vertical tension. Top of surface masked by 12" black drop. Matt White XT1000V and Grey XH600V viewing surfaces are certified to GREENGUARD standards for low chemical emissions into indoor air during product usage. For more information, visit ul.com/gg.



Case of one-piece 22-ga. steel with flat back design and baked-on black finish. Endcaps of 12 ga. black finished steel fully enclosing roller ends and forming universal hanging brackets. Patented by Draper, Inc.

PATENT INFORMATION: available at www.draperinc.com/legal/patents

DOWNLOADABLE 3-PART SPECIFICATIONS: available at www.draperinc.com

Please note: Dimensions of rollers, operators and hardware at manufacturer's discretion.

Dimensions and Data

Audio Visual Format

Size H x W	Case Length	Dowel Length	Net Wt. (lbs.)	Qty.
50" x 50"	68"	60 7/8"	30	
60" x 60"	78 3/4"	7 17/8"	35	
70" x 70"	89"	82 7/8"	40	
84" x 84"	104 1/4"	96 7/8"	50	
72" x 96"	115"	108 7/8"	55	
96" x 96"	117 3/4"	110 3/8"	60	
7' x 9'	128 1/4"	120 7/8"	60	
9' x 9'	129 3/4"	122 7/8"	65	
8' x 10'	141 3/4"	134 3/8"	70	
10' x 10'	143 1/2"	136 5/8"	75	

Methods Of Installation/Case Dimensions

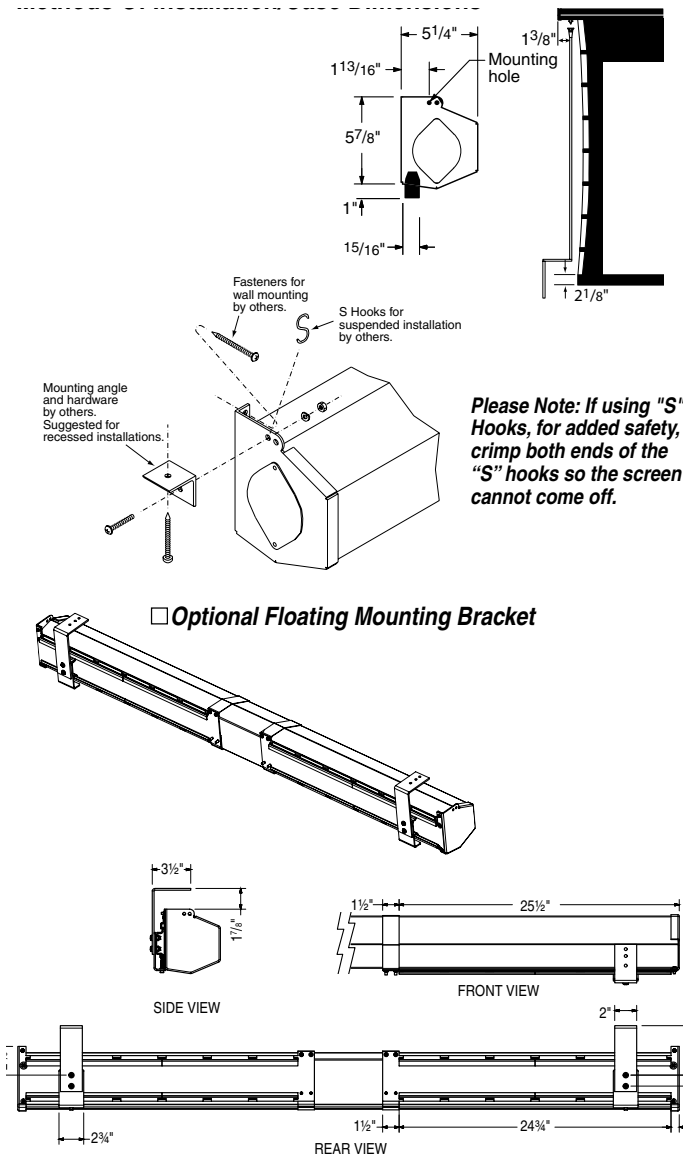

Please Note: If using "S" Hooks, for added safety, crimp both ends of the "S" hooks so the screen cannot come off.

Nominal Diagonal	Image Area HxW	Case Length ¹	Dowel Length ¹	Net Wt. (lbs.)	Qty.
NTSC Video Format (4:3)					
6'	42 1/2" x 56 1/2"	74"	67 3/8"	35	
7'	50" x 66 1/2"	84 1/4"	77 3/8"	40	
100"	60" x 80"	97 5/8"	91 7/8"	50	
10'	72" x 96"	115"	108 3/4"	55	
11'	78" x 104"	124 1/4"	116 7/8"	60	
150"	87" x 116"	136 1/4"	130 3/8"	70	
HDTV Format (16:9)					
92"	45" x 80"	97 5/8"	90 7/8"	50	
106"	52" x 92"	110"	102 7/8"	60	
119"	58" x 104"	122"	115 7/8"	65	
133"	65" x 116"	135"	127 7/8"	70	
Custom Size					

Select Viewing Surface

- Matt White XT1000V (1.0 gain): GREENGUARD Gold certified
- Grey XH600V (0.6 gain) (Thru 9' x 9'): GREENGUARD Gold certified
- Pearl White CH1900V (1.7 gain) (Thru 9' x 12'): Optional
- Pure White XT1300V (1.3 gain): Optional
- Rear Projection Surface: Optional _____
- Other: _____

Optional Accessories

- Additional Drop: _____ (Beyond standard 12")
- Total Drop: _____ (Standard 12" + Additional drop)
- (Total screen height cannot exceed 12'; extra drop increases length of case)
- Black (standard)
 - Same color as viewing surface
- Please Note:** Extra drop increases both case and dowel lengths.

- Height from bottom of screen to floor: _____
- Optional Floating Mounting Brackets (for wall and ceiling)

PROJECT: _____

ARCHITECT: _____

CONTRACTOR: _____

SUPPLIER: _____

DATE: _____ **REVISED:** _____