

Specifications

QUANTITY: _____ **SIZE:** _____ h. x _____ w. (overall size) projection screen, overall dimension to include 2" border. Permanent wall mounting type. Snap button style projection surface with 2" black vinyl borders on all four sides, snaps set on 6" centers. Complete with 1" square tubular aluminum frame equipped with snaps to fit surface. Projection surface to be flame and mildew resistant.

Matt White XT1000V and Grey XH600V viewing surfaces are certified to GREENGUARD standards for low chemical emissions into indoor air during product usage. For more information, visit ul.com/gg.

Truss Style Construction (Large sizes only): As above, except surface shall have 6" black vinyl borders, and frame shall consist of 1" square tubular aluminum welded and reinforced in a 6" wide double truss.

Downloadable 3-part specifications: available at www.draperinc.com

Specifications subject to change without notice.



Select Viewing Surface:

OptiFlex (Flexible)

- Matt White XT1000V (1.0 gain) (GREENGUARD Gold Certified)
- Grey XH600V (0.6 gain) (GREENGUARD Gold Certified)
- Pure White XT1300V (1.3 gain)

CineFlex (Rear/Dual Projection)

- CineFlex CH1200V (1.2 gain)
- CineFlex White XT700V (0.7 gain)
- Other: _____

ClearSound (Acoustically Transparent)

- ClearSound NanoPerf XT1000V (1.0 gain)
- ClearSound White Weave XT900E (0.9 gain)
- ClearSound Grey Weave XH600E (0.6 gain)
- Other: _____

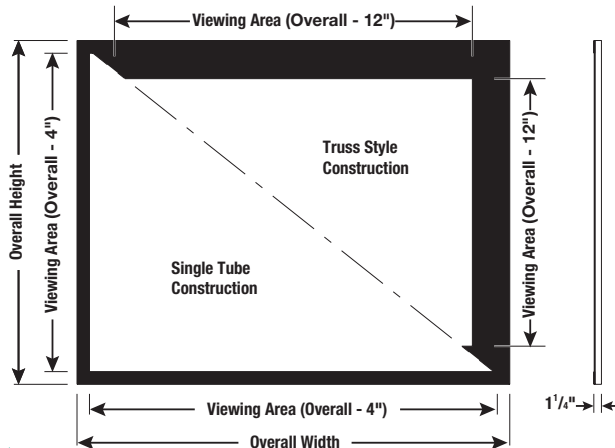
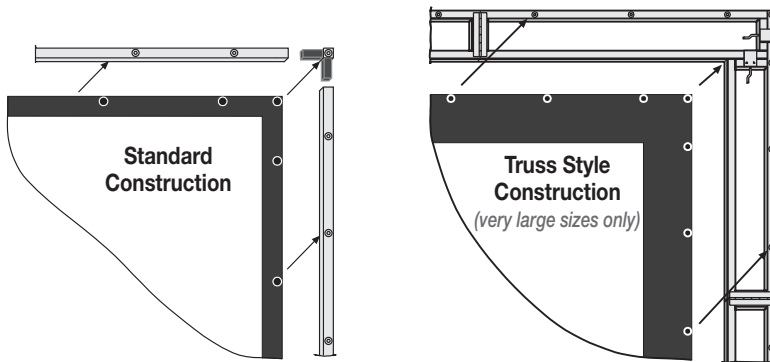

Dimensions and Data

16:10 Format

Nominal Diagonal	Image Area (H x W)	Overall Size	Net Wt. (lbs.)	Qty.
67"	35 1/4" x 56 1/2"	39 1/4" x 60 1/2"	19	
76"	40" x 64"	44" x 68"	20	
85"	45" x 72"	49" x 76"	21	
94"	50" x 80"	54" x 84"	22	
109"	57 1/2" x 92"	61 1/2" x 96"	26	
113"	60" x 96"	64" x 100"	26	
123"	65" x 104"	69" x 108"	28	
137"	72 1/2" x 116"	76 1/2" x 120"	30	
165"	87 1/2" x 140"	91 1/2" x 144"	35	

16:9 HDTV Format

Nominal Diagonal	Image Area (H x W)	Overall Size	Net Wt. (lbs.)	Qty.
65"	31 3/4" x 56 1/2"	35 3/4" x 60 1/2"	19	
73"	36" x 64"	40" x 68"	20	
82"	40 1/2" x 72"	44 1/2" x 76"	20	
92"	45" x 80"	49" x 84"	22	
100"	49" x 87"	53" x 91"	24	
106"	52" x 92"	56" x 96"	26	
110"	54" x 96"	58" x 100"	28	
119"	58" x 104"	62" x 108"	30	
133"	65" x 116"	69" x 120"	32	
161"	79" x 140"	83" x 144"	34	
193"	95" x 169"	99" x 173"	45	
220"	108" x 192"	112" x 196"	54	

4:3 NTSC Video Format

Nominal Diagonal	Image Area (H x W)	Overall Size	Net Wt. (lbs.)	Qty.
6"	43" x 57"	51" x 65"	24	
6 1/2'	47" x 63"	55" x 71"	25	
7 1/2'	54" x 72"	62" x 80"	27	
100"	60" x 80"	68" x 88"	28	
10'	72" x 96"	80" x 104"	30	
11'	78" x 104"	82" x 108"	34	
150"	90" x 120"	98" x 128"	36	
15'	108" x 144"	116" x 152"	43	
200"	120" x 160"	124" x 164"	48	
240"	144" x 194"	156" x 206"	100	
25'	180" x 240"	192" x 252"	172	

CinemaScope Format (2.35:1)

Nominal Diagonal	Image Area (H x W)	Overall Size	Net Wt. (lbs.)	Qty.
115"	45" x 105 3/4"	49" x 109 3/4"	39	
132"	52" x 122"	56" x 126"	46	
148"	58" x 136 1/4"	62" x 140 1/4"	50	
153"	60" x 141"	64" x 145"	55	
166"	65" x 152 3/4"	69" x 156 3/4"	57	

Custom Size

--	--	--	--	--

Overall Frame Size = _____ H x _____ W
 Overall Viewing Area = _____ H x _____ W



PROJECT: _____

ARCHITECT: _____

CONTRACTOR: _____

SUPPLIER: _____

DATE: _____ REVISED: _____